

## FEATURES

- High short circuit capability, self limiting short circuit current
- IGBT CHIP(T4 Fast Trench+Field Stop technology)
- $V_{CE(sat)}$  with positive temperature coefficient
- Fast switching and short tail current
- Free wheeling diodes with fast and soft reverse recovery
- Low switching losses
- $T_{vj\ max} = 175^{\circ}C$

## APPLICATIONS

- High frequency switching application
- Medical applications
- Motion/servo control
- UPS systems



## ABSOLUTE MAXIMUM RATINGS

$T_c=25^{\circ}C$  unless otherwise specified

| Symbol       | Parameter                         | Test Conditions                         | Values   | Unit   |
|--------------|-----------------------------------|---|----------|--------|
| <b>IGBT</b>  |                                   |   |          |        |
| $V_{CES}$    | Collector - Emitter Voltage       | $T_{vj}=25^{\circ}C$                    | 1200     | V      |
| $V_{GES}$    | Gate - Emitter Voltage            |   | $\pm 20$ | V      |
| $I_c$        | DC Collector Current              | $T_c=25^{\circ}C$                       | 600      | A      |
|              |                                   | $T_c=80^{\circ}C$                       | 400      | A      |
| $I_{CM}$     | Repetitive Peak Collector Current | $t_p=1ms$                               | 800      | A      |
| $P_{tot}$    | Power Dissipation Per IGBT        |   | 2100     | W      |
| <b>Diode</b> |                                   |   |          |        |
| $V_{RRM}$    | Repetitive Reverse Voltage        | $T_{vj}=25^{\circ}C$                    | 1200     | V      |
| $I_{F(AV)}$  | Average Forward Current           | $T_c=25^{\circ}C$                       | 600      | A      |
|              |                                   | $T_c=80^{\circ}C$                       | 400      | A      |
| $I_{FRM}$    | Repetitive Peak Forward Current   | $t_p=1ms$                               | 800      | A      |
| $I^2t$       |                                   | $T_{vj} = 125^{\circ}C, t=10ms, V_R=0V$ | 25000    | $A^2s$ |

## MMG400D120B6HN

### ELECTRICAL AND THERMAL CHARACTERISTICS $T_c=25^\circ\text{C}$ unless otherwise specified

| Symbol        | Parameter   | Test Conditions   | Min.                         | Typ. | Max. | Unit          |
|---------------|---|---|------------------------------|------|------|---------------|
| <b>IGBT</b>   |   |   |                              |      |      |               |
| $V_{GE(th)}$  | Gate - Emitter Threshold Voltage                  | $V_{CE}=V_{GE}, I_C=16\text{mA}$  | 5.4                          | 6    | 6.5  | V             |
| $V_{CE(sat)}$ | Collector - Emitter Saturation Voltage            | $I_C=400\text{A}, V_{GE}=15\text{V}, T_{Vj}=25^\circ\text{C}$   |                              | 2.1  | 2.5  | V             |
|               |   | $I_C=400\text{A}, V_{GE}=15\text{V}, T_{Vj}=125^\circ\text{C}$  |                              | 2.5  |      | V             |
| $I_{CES}$     | Collector Leakage Current                         | $V_{CE}=1200\text{V}, V_{GE}=0\text{V}, T_{Vj}=25^\circ\text{C}$  |                              |      | 2    | mA            |
|               |   | $V_{CE}=1200\text{V}, V_{GE}=0\text{V}, T_{Vj}=125^\circ\text{C}$   |                              |      | 10   | mA            |
| $I_{GES}$     | Gate Leakage Current                              | $V_{CE}=0\text{V}, V_{GE} \pm 15\text{V}, T_{Vj}=125^\circ\text{C}$   | -400                         |      | 400  | nA            |
| $R_{Gint}$    | Integrated Gate Resistor                          |   |                              | 1.9  |      | $\Omega$      |
| $Q_{ge}$      | Gate Charge                                       | $V_{CE}=600\text{V}, I_C=400\text{A}, V_{GE} = \pm 15\text{V}$  |                              | 1.9  |      | $\mu\text{C}$ |
| $C_{ies}$     | Input Capacitance                                 | $V_{CE}=25\text{V}, V_{GE}=0\text{V}, f=1\text{MHz}$  |                              | 25   |      | nF            |
| $C_{res}$     | Reverse Transfer Capacitance                      |   |                              |      | 1.4  |               |
| $t_{d(on)}$   | Turn - on Delay Time                              | $V_{CC}=600\text{V}, I_C=400\text{A},$<br>$R_G = 1.8 \Omega,$<br>$V_{GE} = \pm 15\text{V},$<br>Inductive Load | $T_{Vj} = 25^\circ\text{C}$  | 170  |      | ns            |
|               |   |   | $T_{Vj} = 125^\circ\text{C}$ | 180  |      | ns            |
|               |   |   | $T_{Vj} = 150^\circ\text{C}$ | 190  |      | ns            |
| $t_r$         | Rise Time   | Inductive Load  | $T_{Vj} = 25^\circ\text{C}$  | 75   |      | ns            |
|               |   |   | $T_{Vj} = 125^\circ\text{C}$ | 85   |      | ns            |
|               |   |   | $T_{Vj} = 150^\circ\text{C}$ | 90   |      | ns            |
| $t_{d(off)}$  | Turn - off Delay Time                             | $V_{CC}=600\text{V}, I_C=400\text{A},$<br>$R_G = 1.8 \Omega,$<br>$V_{GE} = \pm 15\text{V},$<br>Inductive Load | $T_{Vj} = 25^\circ\text{C}$  | 440  |      | ns            |
|               |   |   | $T_{Vj} = 125^\circ\text{C}$ | 490  |      | ns            |
|               |   |   | $T_{Vj} = 150^\circ\text{C}$ | 520  |      | ns            |
| $t_f$         | Fall Time   | Inductive Load  | $T_{Vj} = 25^\circ\text{C}$  | 45   |      | ns            |
|               |   |   | $T_{Vj} = 125^\circ\text{C}$ | 65   |      | ns            |
|               |   |   | $T_{Vj} = 150^\circ\text{C}$ | 75   |      | ns            |
| $E_{on}$      | Turn - on Energy                                  | $V_{CC}=600\text{V}, I_C=400\text{A},$<br>$R_G = 1.8 \Omega,$<br>$V_{GE} = \pm 15\text{V},$<br>Inductive Load | $T_{Vj} = 125^\circ\text{C}$ | 52   |      | mJ            |
|               |   |   | $T_{Vj} = 150^\circ\text{C}$ | 58   |      | mJ            |
| $E_{off}$     | Turn - off Energy                                 | Inductive Load  | $T_{Vj} = 125^\circ\text{C}$ | 22   |      | mJ            |
|               |   |   | $T_{Vj} = 150^\circ\text{C}$ | 24   |      | mJ            |
| $I_{sc}$      | Short Circuit Current                             | $t_{psc} \leq 10\mu\text{s}, V_{GE}=15\text{V}$<br>$T_{Vj}=125^\circ\text{C}, V_{CC}=600\text{V}$             |                              | 1600 |      | A             |
| $R_{thJC}$    | Junction-to-Case Thermal Resistance ( Per IGBT )  |   |                              |      | 0.07 | K /W          |
| <b>Diode</b>  |   |   |                              |      |      |               |
| $V_F$         | Forward Voltage                                   | $I_F=400\text{A}, V_{GE}=0\text{V}, T_{Vj} = 25^\circ\text{C}$  |                              | 1.65 |      | V             |
|               |   | $I_F=400\text{A}, V_{GE}=0\text{V}, T_{Vj} = 125^\circ\text{C}$   |                              | 1.65 |      | V             |
| $t_{rr}$      | Reverse Recovery Time                             | $I_F=400\text{A}, V_R=600\text{V}$  |                              | 500  |      | ns            |
| $I_{RRM}$     | Max. Reverse Recovery Current                     | $di_F/dt=-4000\text{A}/\mu\text{s}$   |                              | 290  |      | A             |
| $E_{rec}$     | Reverse Recovery Energy                           | $T_{Vj} = 125^\circ\text{C}$  |                              | 31   |      | mJ            |
| $R_{thJCD}$   | Junction-to-Case Thermal Resistance ( Per Diode ) |   |                              |      | 0.12 | K /W          |

# MMG400D120B6HN

## MODULE CHARACTERISTICS

$T_C=25^\circ\text{C}$  unless otherwise specified

| Symbol        | Parameter                  | Test Conditions     | Min. | Typ. | Max. | Unit                    |
|---------------|----------------------------|---------------------|------|------|------|-------------------------|
| $T_{vj\ max}$ | Max. Junction Temperature  |                     |      |      | 175  | $^\circ\text{C}$        |
| $T_{vj\ op}$  | Operating Temperature      |                     | -40  |      | 150  | $^\circ\text{C}$        |
| $T_{stg}$     | Storage Temperature        |                     | -40  |      | 125  | $^\circ\text{C}$        |
| $V_{isol}$    | Insulation Test Voltage    | AC, $t=1\text{min}$ |      | 3000 |      | V                       |
| CTI           | Comparative Tracking Index |                     | 350  |      |      |                         |
| Torque        | Module-to-Sink             | Recommended (M6)    | 3    |      | 5    | $\text{N}\cdot\text{m}$ |
| Torque        | Module Electrodes          | Recommended (M6)    | 2.5  |      | 5    | $\text{N}\cdot\text{m}$ |
| Weight        |                            |                     |      | 300  |      | g                       |

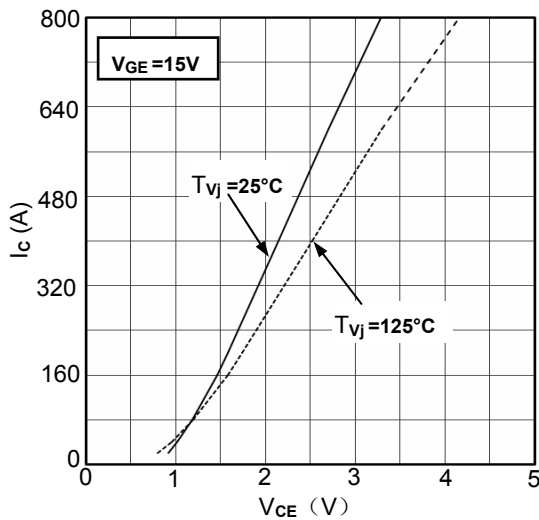

Figure1. Typical Output Characteristics

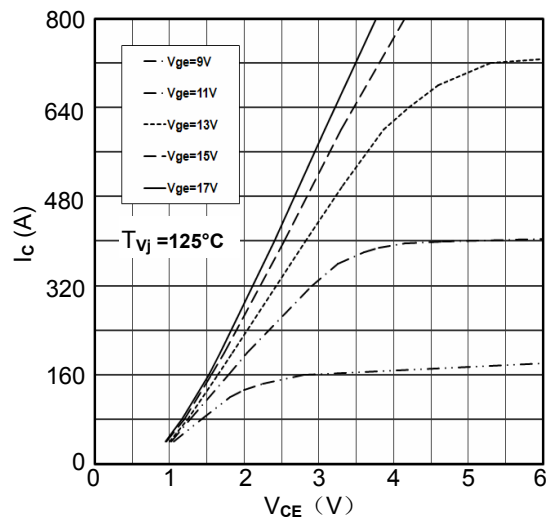

Figure2. Typical Output Characteristics

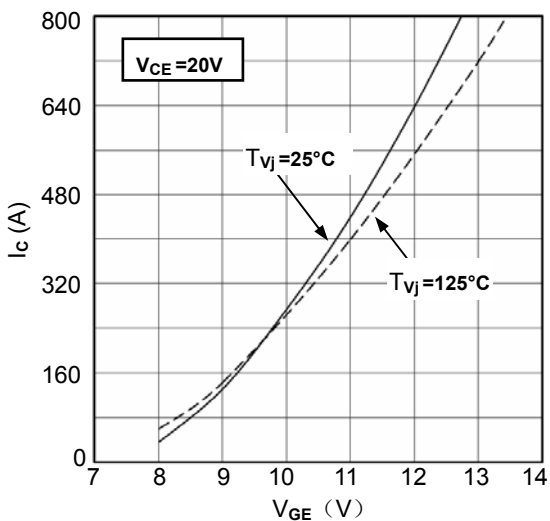

Figure3. Typical Transfer characteristics

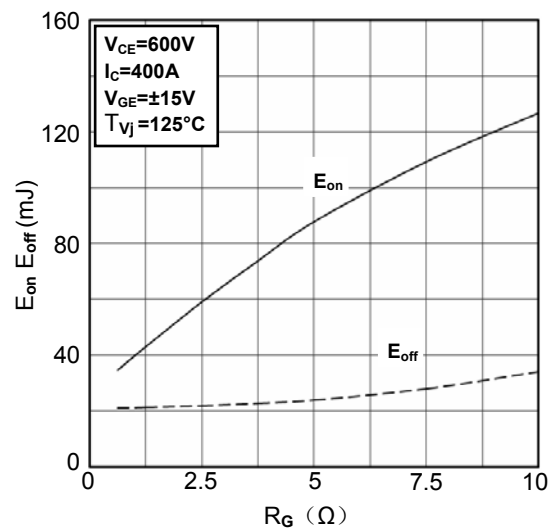

Figure4. Switching Energy vs. Gate Resistor

# MMG400D120B6HN

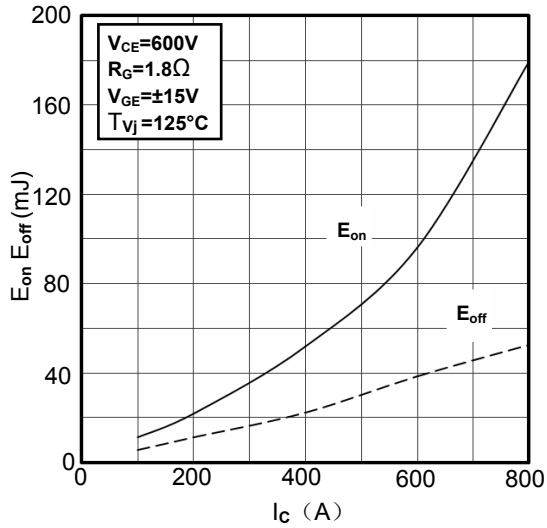

Figure 5. Switching Energy vs. Collector Current

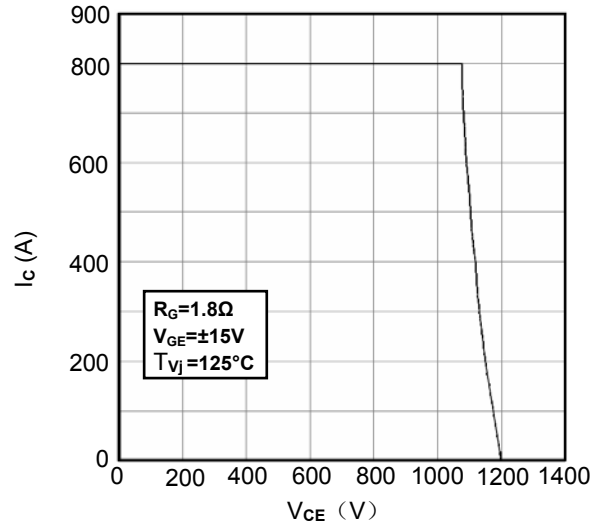

Figure 6. Reverse Biased Safe Operating Area

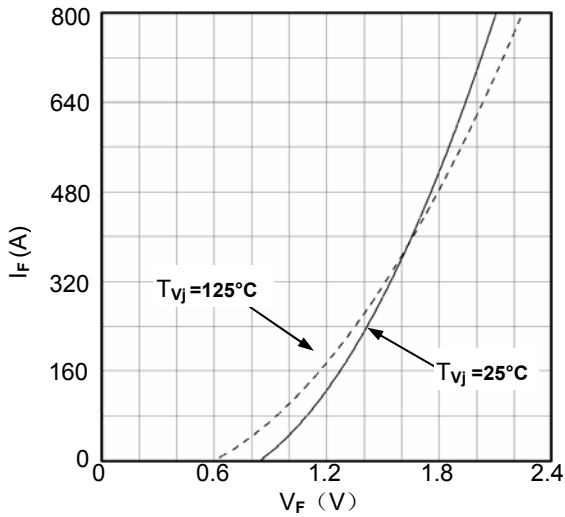

Figure 7. Diode Forward Characteristics

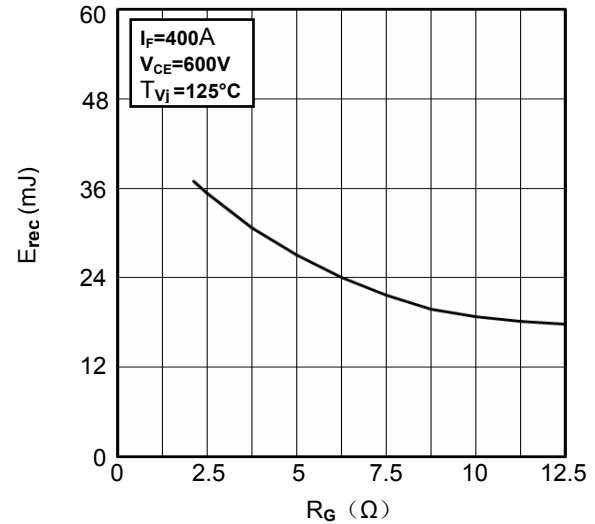

Figure 8. Switching Energy vs. Gate Resistor

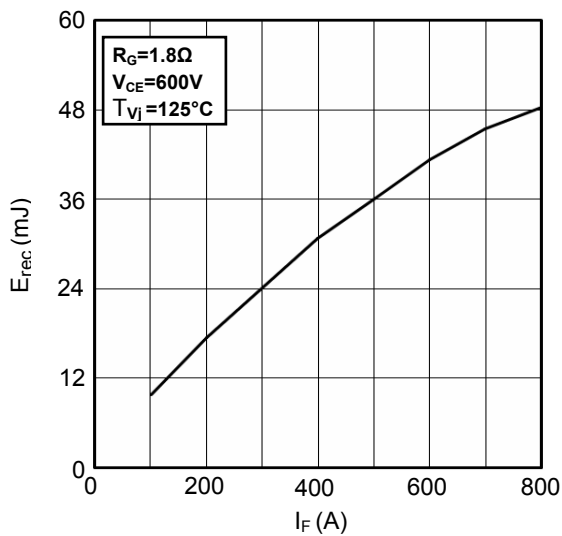

Figure 9. Switching Energy vs. Forward Current

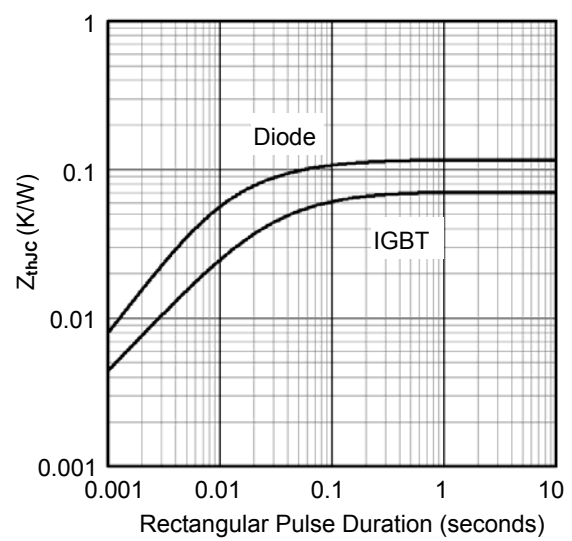

Figure 10. Transient Thermal Impedance

# MMG400D120B6HN

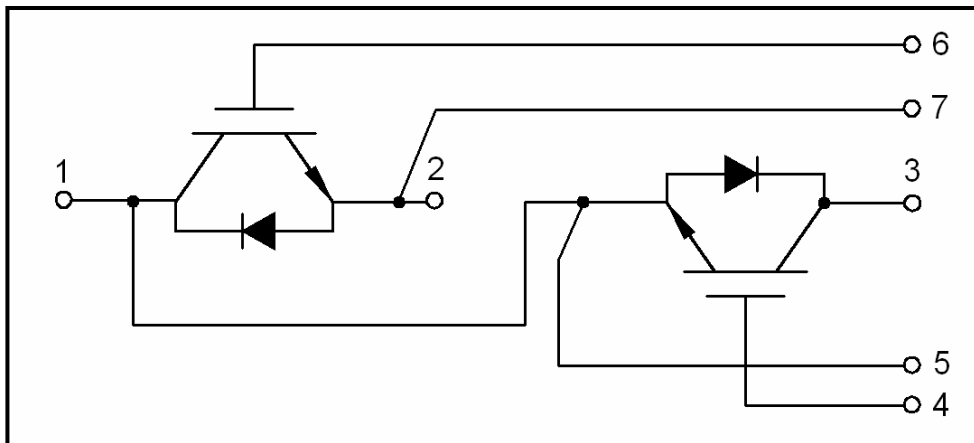
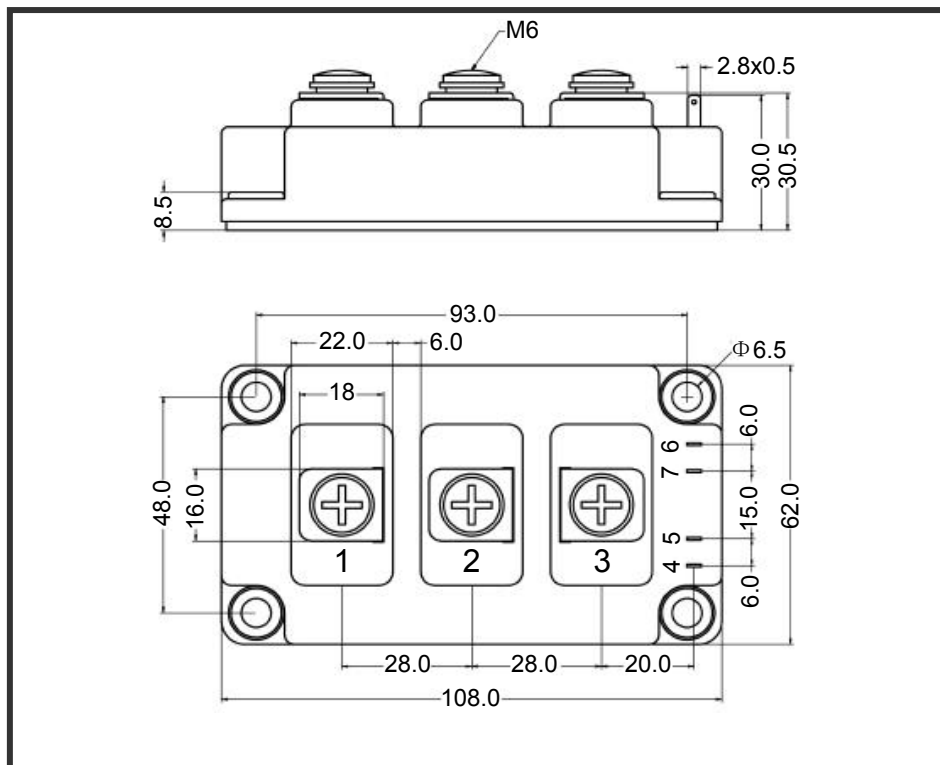

Figure11. Circuit Diagram



Dimensions (mm)  
Figure12. Package Outline